

Dimensions in inches
Not to be used for construction
purposes.

General Arrangement Dimensions

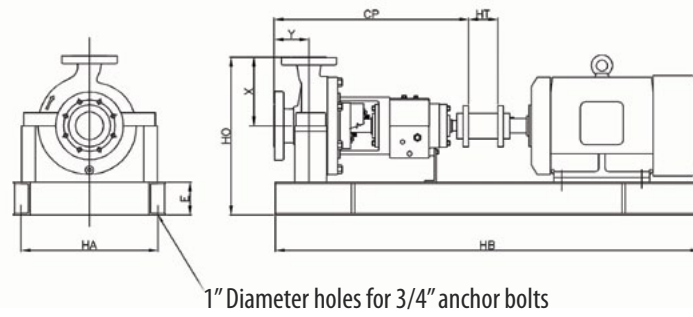

Pump size	Discharge ins	Suction ins	SD ins	T ins	Pump Wt. lbs.
1.5x3x7	1.5	3	<u>17</u>	4	220
3x4x7	3	4	22	5.5	300
2x3x9	2	3	20	5	285
3x4x9	3	4	<u>22</u>	5.5	350
4x6x9	4	6	28	7	475
2x3x11	2	3	<u>23</u>	5	350
3x4x11	3	4	25	6	400
4x6x11	4	6	<u>32</u>	7	500
6x8x12	6	8	38	9	900
2x3x13	2	3	24	5.5	450
3x4x13	3	4	28	6	550
4x6x13	4	6	30	7	650
6x8x15	6	8	44	10.5	1100
8x10x15	8	10	53	12.5	1400
3x4x16	3	4	30	6	850
4x6x16	4	6	39	8.5	900
4x6x18	4	6	39.5	11	1200
6x10x18	6	10	50	11	1500
8x10x18	8	10	58	14	1750
10x12x18	10	12	60	15	2100
4x6x21	4	6	42	8.5	1350
6x10x21	6	10	56	12.5	1800
8x10x21	8	10	60	14	2100
8x12x24	8	12	65	15.75	3000
8x10x27	8	10	65	14	3500
10x14x27	10	14	78	18	5000

Pump size	Y ins	X ins	CP ins	HT ins	HO ins	HB ins	HA ins	E ins	Pump Wt. lbs.
1.5x3x7	5.5	9	27.5	7	27	60	27	6	1100
3x4x7	5.5	9.5	27.5	7	27.5	60	27	6	1200
2x3x9	5.5	9.5	27.5	7	28	60	27	6	1250
3x4x9	5.5	10.5	27.5	7	30.5	60	27	6	1300
4x6x9	7	13	29	7	33	60	27	6	1400
2x3x11	6	11.5	34.5	7	31	84	27	6	1400
3x4x11	6	11.5	34.5	7	31	84	27	6	1500
4x6x11	7	14.5	35.5	7	35	84	27	6	1600
2x3x13	7	12.5	35.5	7	32	84	27	6	1500
3x4x13	7	13.5	35.5	7	33	84	27	6	1600
4x6x13	7	15.5	35.5	7	35	84	27	6	1700
6x8x13	8	17.5	36.5	7	39	96	33	6	2050
6x8x15	8.5	19	37	7	40	96	33	6	2250
8x10x15	9	23	37.5	9	46	96	33	6	2600
3x4x16	7	14.5	35.5	7	36	96	33	6	2200
4x6x16	7	15	35.5	7	40	96	33	6	2300
6x10x18	9	21	37.5	9	47	96	33	6	2600
8x10x18	11	20	46	9	47	108	46	8	3100
10x12x18	12	24	47	9	50	108	46	8	3300
4x6x21	8	20	36.5	7	50	108	46	8	3100
6x10x21	9.5	24	44.5	9	50	108	46	8	3350
8x10x21	9.5	26	44.5	9	52	108	46	8	3500
8x10x24	9.5	28	44.5	9	58	108	46	8	3850
8x10x27	9.5	28	44.5	9	60	108	46	8	4200
10x14x27	14	35	49	9	65	120	52	8	4300



Vertical and horizontal centrifugal process pumps

NOTE: Pumps do not meet standard ASME B73.1 nor ASME B73.2 dimension criteria universally. See individual certified dimensions for pumps.



www.westpower.ca

Calgary | 4451 – 54 Ave SE | Calgary, AB | T2C 2A2 | 403.720.3300

The Mabre centrifugal pump is designed to dominate the most rigorous applications in oil and gas, mining, petrochemical, as well as other industries. Utilizing features generally reserved for highly engineered API 610 pumps, we are able to offer reliable, quality, low maintenance horizontal and vertical process pumps.

Rugged enough to handle more difficult and dangerous applications than typical ASME pumps, we offer impeller diameters ranging from seven inches (178 mm) to 27 inches (685 mm) and flows exceeding 6,000 USGPM (1,360 m³/hr). Mabre is THE pump you can rely on for the most demanding services.

Westpower Heavy Duty Horizontal (WPH-OH1):

- Overhung, end suction, top centre-line discharge.
- 29 models, grouped around three standard bearing frames.
- Available with foot or centre-line mounting and either API 682 or ASME B73.1M seal chamber dimensions.
- All steel with fully enclosed impeller capable of accepting API or ASME cartridge seals.
- Engineered to compliment the vertical in-line range.

WPV Vertical In-line Process Pump:

- Single stage, side suction, side discharge.
- Designed for medium to heavy industrial and petrochemical applications.
- Built to ASME B73. 2 dimensions.
- 26 models, grouped around six standard shaft designs
- Simplified piping that does not require a foundation or bedplate.
- Available in five basic versions and each version can be supplied with a standard 275psi casing or a heavy duty 600psi XH casing.

WPVB-OH3:

- Flexible-coupled, vertical in-line, centrifugal pump.
- Robust bearing housing arrangement makes this design particularly suitable for liquids with traces of solids/erosive materials.
- Cylindrical roller radial bearing provide a basic L10 rating of 25, 000 hours.
- Housing is sealed with labyrinth bearing isolators and is arranged for grease or oil mist lubrication.

WPVR-OH4:

- Rigid coupled pump for use with LP-base motors.

- Engineered design allows for replacement of the impeller bearing and mechanical seal without removing the motor.

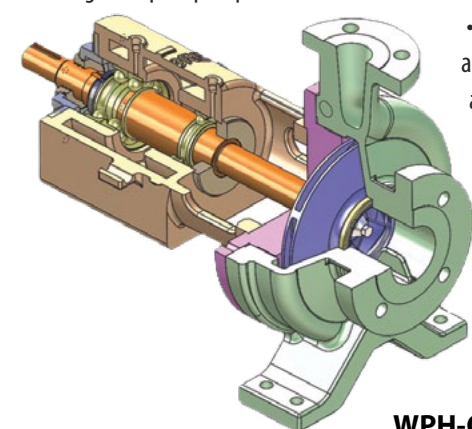

WPH-OH1

Performance Ranges

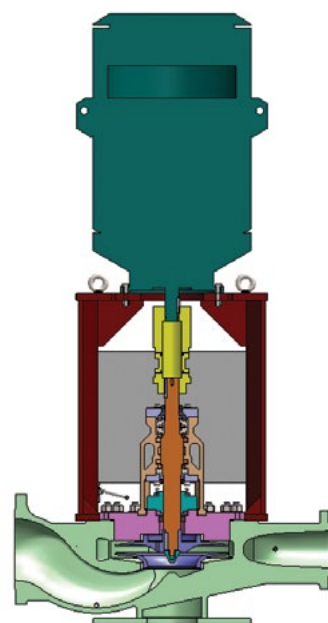
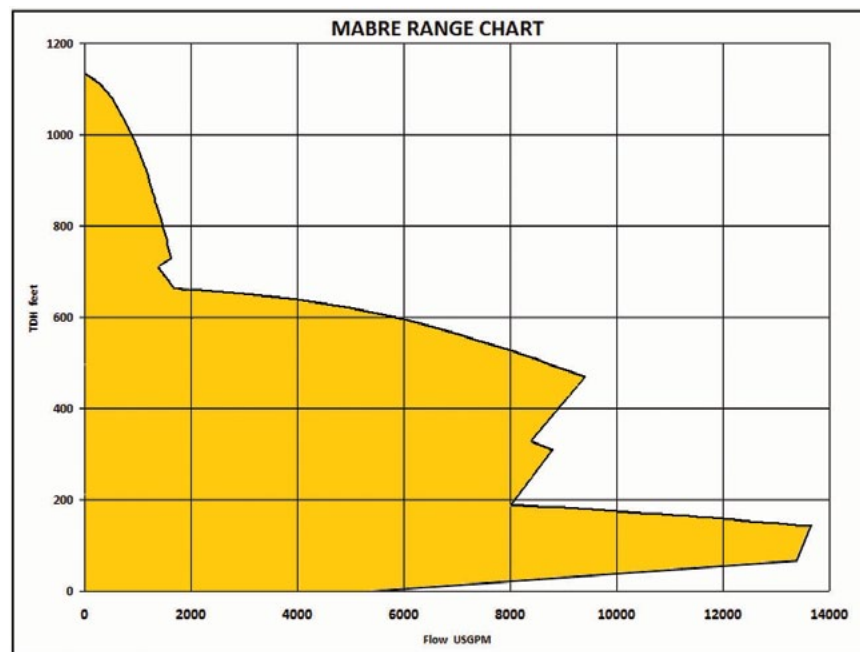

WPVB-OH3

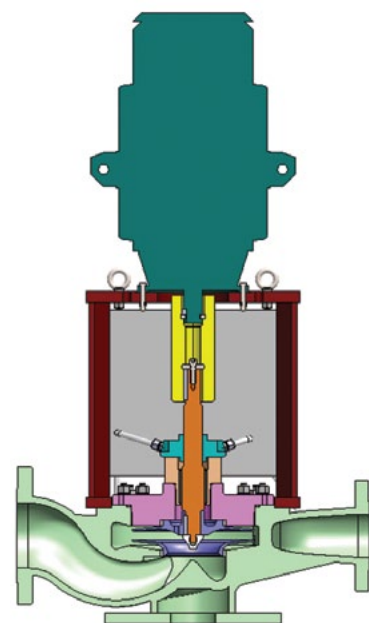

WPVR-OH4

Design Features

	WPH-OH1	WPVB-OH3	WPVR-OH4
Materials	• Full Carbon Steel construction as a standard. Upgrades to 12% Chrome (410 SS), 316 SS, Duplex SS and other materials available upon request		
Casing	• Standard 150# suction and discharge nozzles • Optional 300# nozzles available • Standard 275 PSI MAWP with 150# flanges and 500 PSI MAWP with 300# flanges • Upgrade available to 600 PSI MAWP (1800rpm hydraulic max speed) and 720 PSI MAWP (3600rpm hydraulic max speed)		
Casing Mount	• Foot mount with optional center-line mount	• In-line with piping	
Cover	• API style through bolted cover with metal to metal contact for increased robustness and safety		
Flange Loading	• ½ X API nozzle loads standard • 1X API nozzle loads available with upgraded HD base plate	• 1X API nozzle loads as a standard • Upgrade to 2X API nozzle loads available upon request	
Impeller	• Fully enclosed for wider operating range, better efficiency, better NPSH, and less ongoing maintenance • Static and dynamically balanced to ISO G1.0 (4W/n)		
Shaft	Solid, one-piece sleeveless design		
Wear Rings	• Replaceable casing and cover wear rings • Integral impeller wear rings		
Bearings/Bearing Housing	• Carbon steel bearing housing construction • Duplex 40° back-to-back angular contact thrust bearing • Deep groove radial bearing • API bearing life (25,000 hrs) • API style labyrinth seals	• Cartridge mounted carbon hydrodynamic impeller bearing	
Bearing Lubrication	• Oil bath or oil mist	• Grease or oil mist	• Product lubricated
Mechanical Seal	• ASME or API 682 compliant cartridge single and dual seals		
Seal Flush Plan	• Any ASME or API 682 seal flush plan		
Coupling	• Any flexible coupling		• Two-piece, stainless steel rigid coupling
Coupling Guard	• Removable, non-sparking		

